

SERVICE-LETTER

November 24, 1980

H 20 E - 5

page 1 (3)

REASON Transfer of cylinder head temperature (CHT) sensor.

EFFECTIVITY PIK-20 E serial numbers 20203-20248.

DESCRIPTION Both cylinders run equally warm when the aircraft is moving fast enough ie. flying. Stationary the back cylinder is warmer than the front one (at medium rpm). By moving the CHT-sensor to the back cylinder, the CHT-indicator is registering always the temperature of the hotter cylinder.

COMPLIANCE Recommended

INSTRUCTIONS Remove the CHT-sensor which is under the front sparkplug.
Draw the wire carefully out so that the sensor reaches the back cylinder.
In order to stretch the wire, the wire clamps must be removed.
Bind the wire bundle when enough of the CHT-wire is drawn out.
Check that all control lines move freely without chafing wires.
Cover the back spark plug hole using a cork or a screw plug.
For milling use fine-toothed cutter with a spherical head \varnothing 8-12 mm.
Use eye protectors when milling.

Mill metal from between the spark plug hole and decompression valve hole, using the front cylinder as a model (see figure 1), until the CHT-sensor fits well under the spark plug.

NOTE! Sharp edged notches are not allowed. If they are formed while milling they must be filed down.

Clean the cylinder head careful from the aluminium chips created while milling.

Make a support plate, according to figure 2, from 1 mm stainless steel and mount it to the support of the front sparkplug cover.

Draw the CHT-wire through the support hole using a through insulator.

Attach the through insulator to the support plate.

Connect the CHT-wires and shield the joint.

MATERIALS

- A through insulator
- Stainless steel sheet, 1 mm.
- Wire clamps.
- Shrink tube for shielding the CHT-wire joint.

WEIGHT and

BALANCE

No effect.

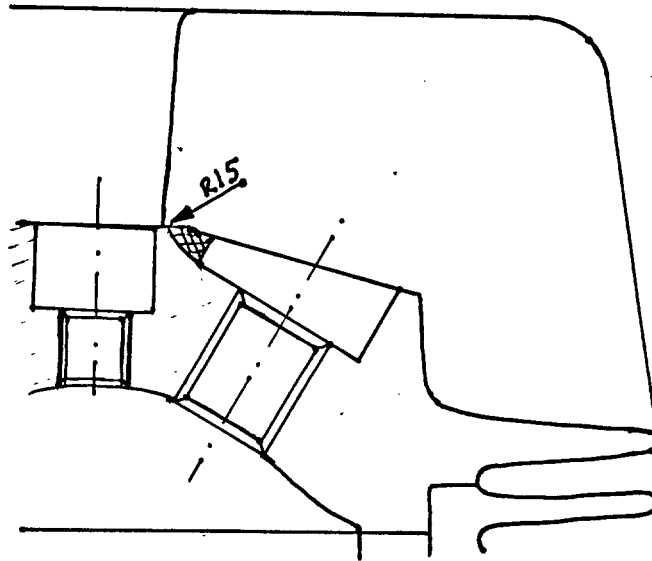

Figure 1.

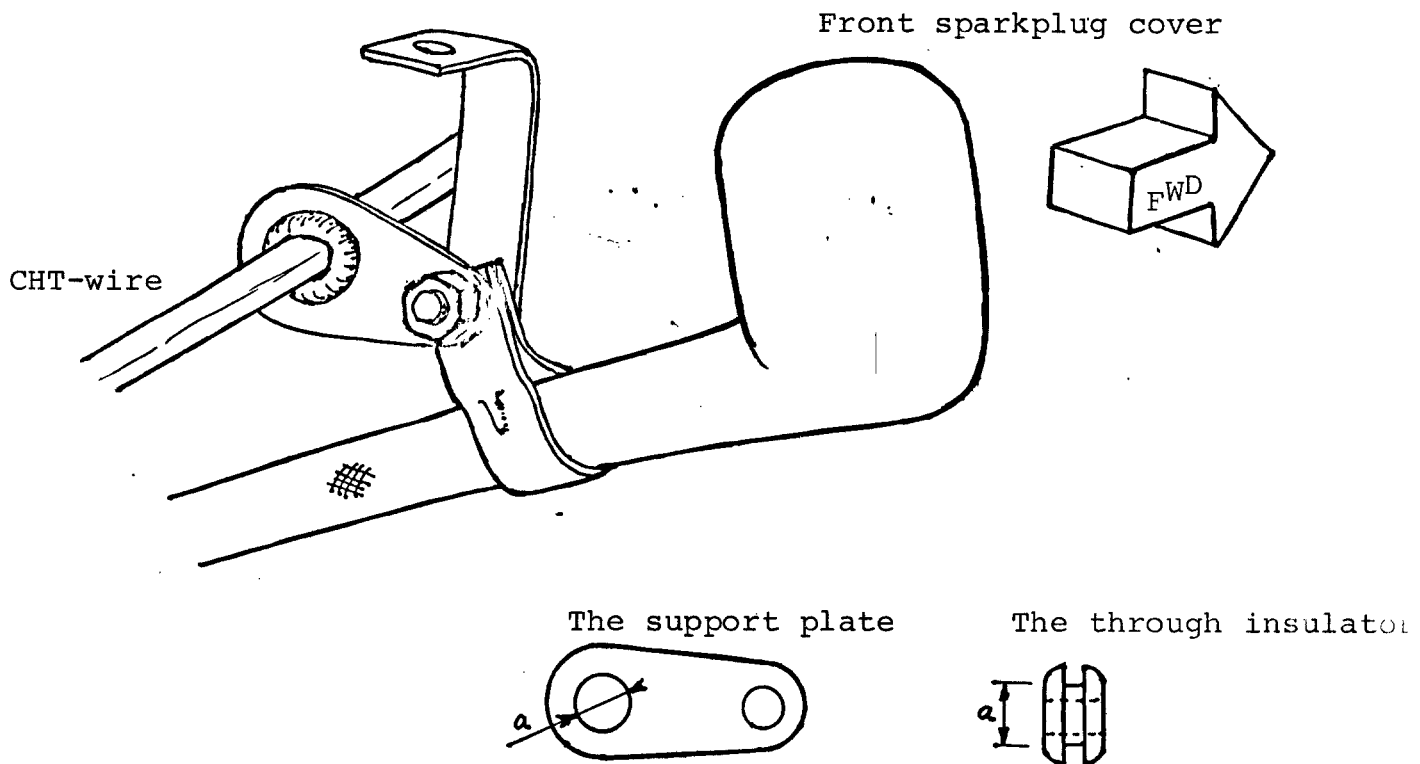

Figure 2.