

PIK-20 E Service manual

SERVICE MANUAL
for
SELF LAUNCHING SAILPLANE
PIK-20 E

EIRI KY

Kisällinkatu 8
SF-15170 Lahti 17

SERVICE MANUAL
for
SELF LAUNCHING SAILPLANE
PIK-20 E

SERIAL NO:

REGISTRATION:

This sailplane must be serviced in compliance with this Manual.

Approved by National Board of Aviation, Finland

EIRI KY

Kisällinkatu 8
SF-15170 Lahti 17

PIK-20 E Service manual

LOG OF REVISIONS

Any revision of the present Manual must be recorded in the following table. The new amended text in the revised page will be indicated by a black vertical line in the left hand margin and the Revision No. and date will be shown on the bottom of the page.

Rev No.	Revised Pages	Description of Revision	Date	Signed
Edition 2	All pages	New Edition (Replaces previous edition dated Nov. 1978)		
Rev 1	II-8, II-9	New fuel tank. S/N:s 20215, 20221 and up	Jan 80	EIRI
Rev 2	II-7	Assembly of starter emergency relay S/N:s 20213, 20214, 20217 and up	Jan 80	EIRI
Rev 3	II-10	Change in water tank volyme S/N:s 20247 and up	Jan 80	EIRI
Rev 4	II-31	Revised control surfaces balancing instructions. S/N:s 20257 and up.	Mar 80	EIRI

EIRI KY

Kisällinkatu 8
SF-15170 Lahti 17

PIK-20 E Service manual

II SERVICE MANUAL TABLE OF CONTENTS	Page
1. ASSEMBLY AND DISASSEMBLY	II- 1
1.1 Preparation	II- 1
1.2 Wing assembly	II- 3
1.3 Tailplane assembly	II- 3
1.4 Disassembly	II- 4
2. SYSTEM DESCRIPTION	II- 5
2.1 Powerplant	II- 5
2.2 Electrical system	II- 6
2.3 Fuel system	II- 8
2.4 Water ballast	II-10
3. DAILY CHECK	II-11
4. CARE AND MAINTENANCE	II-12
4.1 General care	II-12
4.2 Powerplant maintenance	II-13
4.3 Sailplane maintenance	II-26
4.4 After gear-up landing and after rough landing	II-30
4.5 Balancing of control surfaces	II-30
5. WEIGHT AND BALANCE	II-32
5.1 General	II-32
5.2 Weighing procedure	II-32
5.3 Calculations for actual empty weight and moment	II-35
5.4 Calculations for minimum and maximum pilot weight	II-35
5.5 Sample Problem: Actual empty weight and moment of the sailplane	II-36
6. TRANSPORTATION OF THE SAILPLANE AND HANDLING ON THE GROUND	II-38
6.1 Transportation	II-38
6.2 Handling on the ground	II-38

EIRI KY

Kisällinkatu 8
SF-15170 Lahti 17

1. ASSEMBLY AND DISASSEMBLY

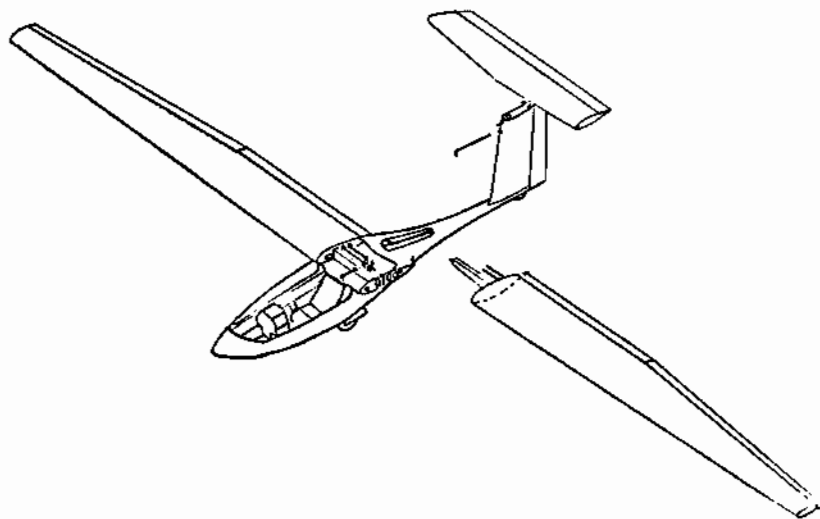

1.1 Preparation

Three or even two persons can easily assemble and disassemble the PIK-20 E. Before assembly prepare the wing assembly tool, clean clothes, grease of mineral or synthetic basis. Clean and grease all fitting surfaces, bolts, pins and control system connections.

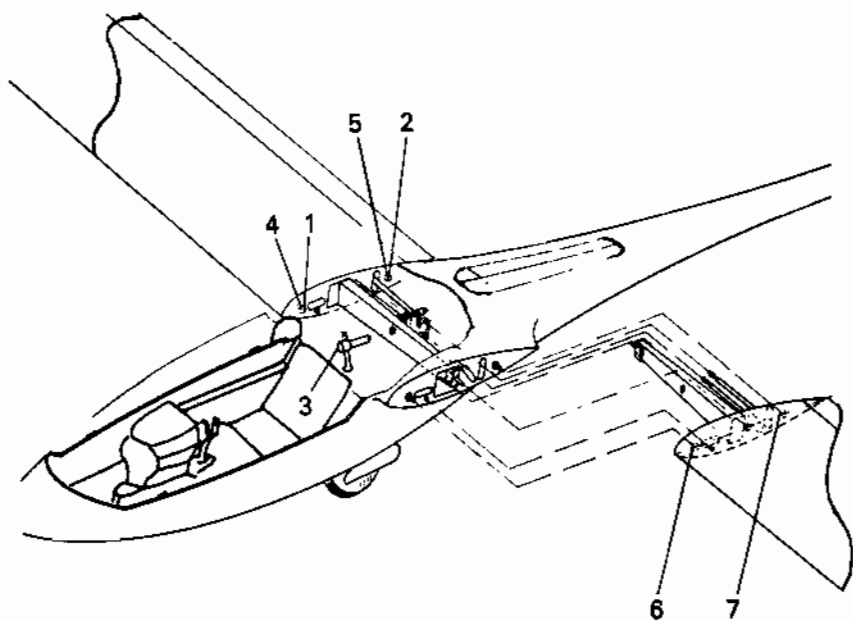

Fig 2

1.2. Wing assembly (Figure 2)

- Insert the right-hand wing ensuring that the wing bevel pins (1) and (2) are in the seats (4) and (5) in the fuselage.
- Insert the left-hand wing in the same way and watch that the bevel pins (6) and (7) go correctly into their seats. Draw the wings together with the wing assembly tool and install the main wing pin and secure it using a Fokker-pin. It is necessary to lift the wing tips when using the assembly tool.
- Connect the flap and airbrake control rods with quick release locks and secure them with Fokker pins.
- Connect the water ballast hoses to the fuselage.
- Install the venturi tube.

1.3. Tailplane assembly (Fig 3)

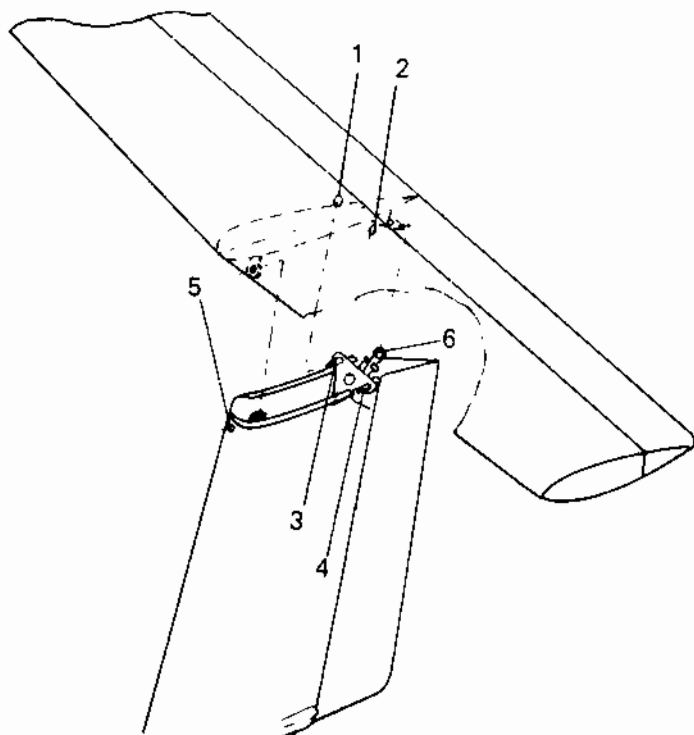

Fig 3

PIK-20 E Service manual

- Insert the horizontal stabilizer by moving the trim and flap lever to the foremost position and by lifting the leading edge up a little and by pushing the ball bearings (1) and (2) on to the pins (3) and (4) on the vertical stabilizer.
- Pull out the locking pin (5) with a tool (Fokker-pin of the wing bolt) and push the leading edge into place. Remove the tool and push the locking pin in. Ensure that the front fitting is engaged and secure the pin using a Fokker-pin.
- Deflect the elevator upwards and connect the elevator control rod (6) and secure it using a Fokker-pin.

1.4. Disassembly

- The wings and horizontal stabilizer are removed in the reverse sequence to assembly.

2. SYSTEM DESCRIPTION

2.1 Powerplant

Engine description:

Type: Rotax 501

Two-cylinders in line two-cycles Otto engine

Air cooled

Oil mixed to fuel lubrication

Single magneto ignition

Propeller driven with a toothed belt reduction 2:1

Electric starter

Alternator

Fuel pump with impulse drive

Engine technical data:

Bore	2 × 72 mm
Stroke	61 mm
Displacement	496.7 cm ³
Compression ratio	10.8 (10.3—11.3)
Ignition system	Bosch-Magneto-Generator, SCP2, 12 V, 140 Watt alternator
Contact breaker gap	0.35—0.45 mm
Ignition timing	2.07 mm ± 0.25, 19° BTC
Spark plugs	NGK B8ES, Champion N3
Spark plug gap	0.4—0.6 mm
Carburetors	Tillotson Membrane carburettor HR Main nozzle Gr. 0.046
Direction of rotation	Counter clockwise facing the engine drive shaft
Starter	Geared starter
Fuel	Min 96 octane (RON) Super gasoline or Aviation gasoline 100LL, twostroke mix
Lubrication	Oil mixed to fuel lubrication, mixing ratio 1:40 with Super twostroke oil
Weight	With muffler and electric starter 33,5 kg

PIK-20 E Service manual

Engine operational data:

Takeoff power	31.7 kW/43 hp/6200 rpm/100 km/h
Max continuous power	29.4 kW/40 hp/6000 rpm/100 km/h
75 % max cont. power	22.1 kW/30 hp/5500 rpm/100 km/h
75 % max cont. power	22.1 kW/30 hp/6000 rpm/135 km/h
Max continuous rotational speed	6000 rpm
Max rotational speed	6800 rpm
Idling rotational speed	appr. 2000 rpm
Cylinder head temperature	Thermoring under spark plug, max 250°C allowed
Fuel consumption	100 % power: appr. 22,4 l/h 75 % power: appr. 17,2 l/h

Propeller:

Propeller model	1. HO 11* 127B 87 2. EP P127/87
Propeller diameter	1270 mm
Propeller type	Two-blade, wooden, fixed pitch

2.2 Electrical system

The 12-volt electrical system includes a 12-volt battery for starting and use during soaring. The engine has an alternator in connection with the magneto. The current is rectified and regulated by a Tympanium-type rectifier, attached to the propeller axle.

The electric starter has 0.4 hp and is geared type.

The electric fuel pump is a solid state type.

Electrical switches are located on the left side of the instrument panel and the fuses are below the switches. The main switch operates the main contactor which is located near the battery in the engine compartment or below the instrument panel.

The starter knob operates the starter contactor, which is situated beside the main contactor.

The ground terminals of the electric fuel pump and the starter contactor are connected to the ground over a microswitch. The engine position operates the microswitch and the switch is connected only when the engine is fully extended.

EIRI KY

Kisällinkatu 8
SF-15170 Lahti 17

PIK-20 E Service manual

FIG 2.1: ELECTRICAL SYSTEM

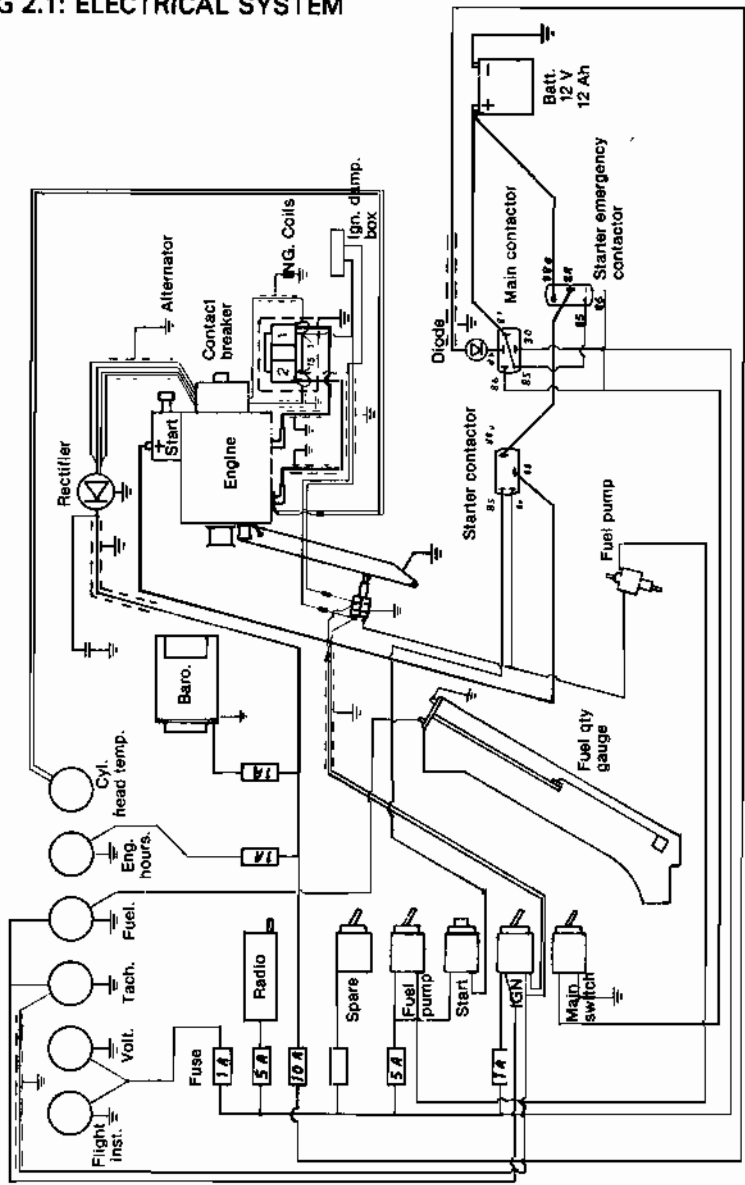

EIRI KY

Kisällinkatu 8
SF-15170 Lahti 17

PIK-20 E Service manual

The engine hourmeter and an optional barograph are operated directly by the alternator. They cannot be switched off and are only operating when the engine is running.

The ignition switch is a dual switch and beside of the function as an ignition shut off, it operates the tachometer and the fuel quantity gauge.

The ignition line is also connected to the microswitch and the ignition is shut off when the engine is not fully extended.

The condition of the battery and the function of the alternator can be checked by the voltage meter. The line between the red and black area corresponds to 12 volts.

2.3 Fuel system

The fuel capacity is 29 litres, of which 28 litres are usable. The fuel tank is situated behind the backrest. Filler opening is on the fuselage between the canopy frame and the wing. The fuel valve is situated on the tank.

The fuel quantity can be checked from the electrical quantity gauge.

The fuel tank vent, in the cap, should be inspected daily prior to first flight that it is free from obstruction. To avoid accumulation of the water and sediment, the fuel in the tank should be examined daily prior to first flight and after refueling, by using the sampler cup provided to drain fuel from the tank. The drain valve is situated on the left fuselage side.

The fuel filter is an inline paper filter type with 16 μm filtration (0.6 micron) and nominal capacity 60 l/h (e.g. Purolator 00610). The filter is in the baggage compartment after the fuel cock. The filter should be changed every 25 hours or yearly.

The auxiliary electric fuel pump is a solid state type and situated down in the engine compartment.

The primary pump is an engine driven impulse type.

The carburettors are provided with a return line to avoid airbubbles in the fuel feed.

Inspect and clean the tank carefully every year.

EIRI KY

Kisällinkatu 8
SF-15170 Lahti 17

FIG 2.2: FUEL SYSTEM

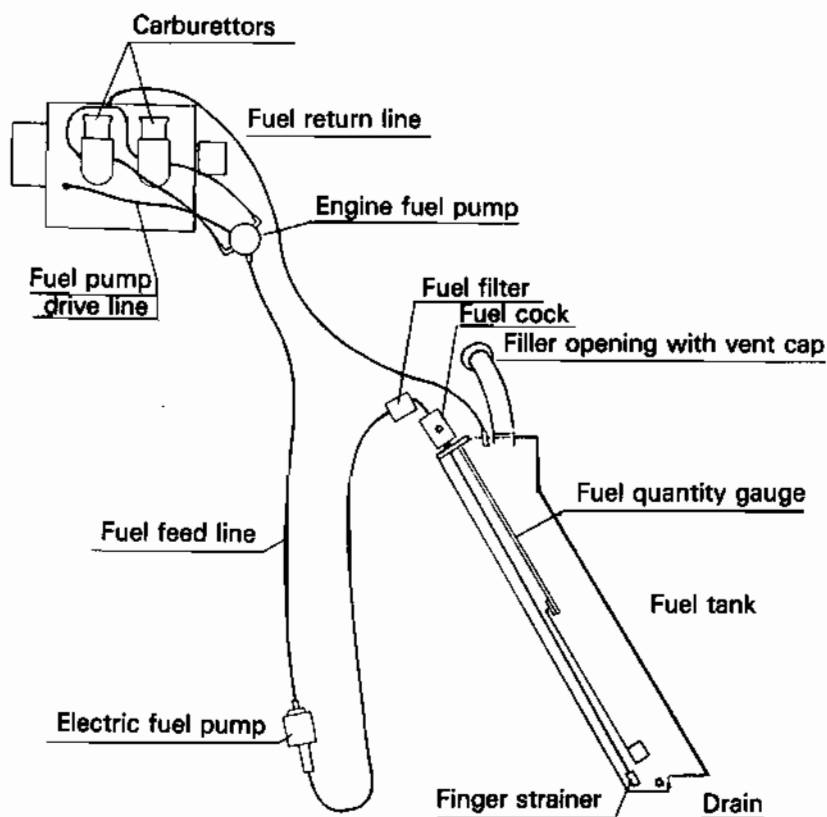

2.4 Water ballast

The water ballast is a four meter long nylon reinforced plastic bag in both wings, fore of the main spar. The capacity of one bag is 40 litres giving a total capacity of 80 litres. The tanks are filled through the draining hole on the underside of fuselage. The water ballast valve is operated by a cable. The operating knob is on the left side auxiliary panel in the cockpit.

Filling instructions:

1. Install the 2—4 m long filling tube with threaded filling connector into the outlet hole.
2. Keep the wing in level. Open the ballast valve and fill the system through a funnel.

Note 1: 1 m is the maximum filling height (distance from the funnel to the wing). Higher pressure than this, 0.1 BAR (0.1 kp/cm²), can cause serious damages to the wing.

No pressurized filling system is allowed.

3. When filled, check the equal amounts (wings stay level).
4. If the amounts are not equal, then keep the valve open and lift the heavier wing and wait for the water to flow. Check, if the wings are not yet in balance, then shake the wing, having the lightest tip down.
5. If the balance is not achieved then you have to put the lightest tip down and let the water flow out through the filling hose.
6. When the amounts are equal, shut the valve and remove the filling hose.

Note 2: When maximum amount of water is needed it is recommended before filling to suck all the air from the system through the filling hose (e.g. with a vacuum cleaner).

3. DAILY CHECK

After the sailplane has been rigged and before the first flight of the day the daily check must be done. The check list and checking procedures are given in the Flight Manual: Normal procedures (5.1, 5.5).

It is important that the daily check is properly done. It is possible that some defect has not been noticed during the monthly check or something has appeared during the previous flights.

Especially after rigging it is important to check that all quick release locks are properly connected and secured. It is best to sign the assembly in the log book.

Cracks in paint may be marks of defects in the structure and all attachments should be checked carefully.

The powerplant with retracting mechanisms should also be checked for cracks and loose bolts and wear.

4. CARE AND MAINTENANCE

4.1 General care

The outside of the sailplane can be kept bright and smooth simply by washing with water and mild soap. Avoid abrasive or harsh detergents. Rinse with clean water and dry with terry-cloth towels or a chamois.

It is always best to keep a good wax layer on the paint to protect the surface from humidity and dirt and also to minimize the "bug" building on the leading edges during flight. A whole plane polish once a year is recommended with car polishing agent or solid polishing wax for acrylic or plastic with polishing machine (be careful of overheating the surface).

When gliding in rain the performance of the sailplane is better if wax is removed. The wax can be removed with waxremover (car motor detergent) or by sanding paper number 600, until the glossy finish of the wings is removed.

Surface tension lowering agents as dish washing detergent can be used on the wing surfaces. Use thin layer and polish it with dry cloth.

The canopy surface may be cleaned according to the following instructions:

1. Use plenty of water to rinse the canopy surface.
2. Wash the acrylic sheet with dish washing detergent or mild soapwater. Use a sponge in spreading the soapwater. Do not rub because dirt scratches the acrylic sheet.
3. Grease and oil spots can be removed with kerosene and a soft cloth.
4. Never clean with a dry cloth.

Note: Never use gasoline, benzine, alcohol, acetone, carbon tetrachloride, lacquer thinner or glass cleaner to clean the plexiglass.

PIK-20 E Service manual

In hot sunshine it is recommended that the sailplane is protected with a light coloured covering.

Prior to hanging, water drain holes, shown in Figure 6, should be inspected for free outlets and cleaned if necessary.

When storing the sailplane in a trailer it is important to see that there is no water laying in the trailer. Felt on fuselage and wing holders should be dry.

There must be ventilation holes in the trailer.

When storing the sailplane for longer periods, it is good to use silica-gel in the trailer and tape the trailer airtight to keep the air dry. It should also be checked that there is no water in the wing. The water bags should be drained carefully and the sealings should be removed from the wing rib to get the air to circulate.

All bare metal parts should be protected with grease.

4.2 Powerplant maintenance

4.2.1 General

The inspection and maintenance of the powerplant and powerplant system depend on the engine hours. Safe operation can be achieved only by following the maintenance instructions given in this Manual. Maintenance periods are 25 and 50 hours (see 4.2.2: Powerplant Maintenance and Inspection Lists).

The spark plugs must be changed twice during the 25 hours maintenance period. The maximum allowed spark plug life is 15 hours.

If the engine use is little, at least the 50 hours maintenance must be done yearly.

Major overhaul period is 300 hours. This overhaul is made by the engine manufacturer or by a manufacturer authorized workshop.

In connection with an engine maintenance at least the monthly check is recommended to be done to the sailplane. The maintenance must be done by a person who at least has sufficient experience of automobile or two-stroke engine maintenance work.

4.2.2 Inspection guide lines

- a) **MOVABLE PARTS** for lubrication, servicing, security of attachment, binding, excessive wear, safetying, proper operation, proper adjustment, correct travel, cracked fittings, security of hinges, defective bearings, cleanliness, corrosion, deformation, sealing and tension.
- b) **FLUID LINES AND HOSES** for: leaks, cracks, dents, kinks, chafing, proper radius, security, corrosion, deterioration, obstruction and foreign matter.
- c) **METAL PARTS** for: security of attachment, cracks, metal distortion, broken spotwelds, corrosion, condition of paint and any other apparent damage.
- d) **WIRING** for: security, chafing, burning, defective insulation, loose or broken terminals, heat deterioration and corroded terminals.
- e) **BOLTS IN CRITICAL AREAS** for: correct torque in accordance with torque values given in 4.2.5, when installed or when visual inspection indicates the need for a torque check.

PIK-20 E Service manual

4.2.3 MAINTENANCE AND INSPECTION LIST

The maintenance and inspection list can be used to sign the completed items. The crossed squares are not to be done.

Notes in the list refer to the Maintenance Instructions 4.2.4.

Reference	No	Item	Engine hours	
			25	50
		PROPELLER		
Note 1	1	Check propeller bolts tightness and secure safety wires		
Note 2	2	Inspect blade and measure difference in track of blades.		
	3	Inspect propeller drive gear and teeth		
Note 3	4	Check play in drive gear bearings		
Note 4	5	Grease drive gear bearings (every 100 hours)	X	
Note 5	6	Inspect toothed belt and check tension	X	
	7	Inspect belt driving gear and teeth		
	8	Inspect belt driving gear lock plate, bolts and lock wires		
		ENGINE		
		Check for marks of leaks (exhaust and fuel). Clean the engine compartment as needed before other service actions are performed.		
	1	Inspect engine air ducts and cooling baffles		
	2	Inspect carburettor box, cover and intake net		
Note 6	3	Inspect crankcase and cylinders		

EIRI KY

Kisällinkatu 8
SF-15170 Lahti 17

PIK-20 E Service manual

Reference	No	Item	Engine hours	
			25	50
	5	Inspect safety wire and attachment and tauten if needed		
	6	Inspect engine retracted position lock		
Note 14	7	Inspect engine brake		
	8	Inspect engine compartment doors		
Note 15	9	Clean and lubricate the engine retracting and door mechanisms (every 100 hours)	X	

FUEL SYSTEM

1	Inspect hoses, attachments, hose clips and inlets		
2	Inspect fuel pump attachments and electric wires		
3	Change fuel filter		
4	Inspect fuel cock and drain valve		
5	Inspect fuel tank, filler opening and ventilation		
6	Inspect electric wiring of the fuel tank		

ELECTRIC SYSTEM

	1	Inspect battery and check acid level		
	2	Inspect battery ventilation		
	3	Clean battery compartment		
	4	Inspect battery terminals and battery attachment		
	5	Inspect wires, switches, fuses and terminals		
Note 16		After a maintenance, check the function of the engine by running up.		

EIRI KY

Kisällinkatu 8
SF-15170 Lahti 17

PIK-20 E Service manual

4.2.4 Notes in powerplant maintenance list

Note 1 Propeller bolts
Propeller bolts tightness should be 15 to 17 Nm. See Propeller Manual.

Note 2 Propeller blade condition and track
For blade condition check, see Propeller Manual. Difference in blade track should not be more than 3 mm measured 10 cm from the blade tip at the trailing edge. See Propeller Manual.

Note 3 Play in propeller drive gear bearings
There should be no play in the bearings when moving the propeller blade back and forward. The bearings can be tightened by adjusting the bearing nut located under the propeller. The nut is tightened when turning counter-clockwise (left). Do not bend the same lock washer tab twice. Do not overtighten the bearings.

Note 4 Lubricating the propeller drive gear bearings
Remove propeller and the toothed drive belt (see Note 5). Open the bearing nut by turning clockwise. Use an extractor to remove the gear and bearings. Turn the gear while removing in order not to defect the bearings.

Clean the bearings and check condition of bearings, gear and shaft. Apply ball bearing grease and mount the gear.

The gear can be warmed to +50°C (+120°F) to ease the mounting. Check that the back bearing is in right position. The back bearing protecting plate can be sealed by using e.g. silicone glue.

When the gear is mounted, check that the back bearing inner ring is in the right position on the shaft.

Mount the drive belt and run the engine for a while and retighten the bearings when the gear has cooled down.

Do not overtighten the bearings. Check that the gear is turning lightly.

PIK-20 E Service manual

Note 5 The toothed drive belt

When properly installed and when clean, the belt requires little maintenance.

If the edges are worn it can be due to misalignment. Check also the drive gear flange for straightness.

When the belt is in right tension, a 60 N force applied at the midpoint of the span between the two pulleys should bend the belt 2.5 mm (14 lbs, 3/32 in).

Excessive belt tension may cause excessive wear between belt teeth. A too loose belt may lead to jumping of teeth and cause vibrations.

Normally improper tension is a mark of some other defect (improper gear center to center distance).

Changing the toothed drive belt

When the belt has worn too much, it should be changed.

Remove the propeller and the flange at the small belt drive gear. Check that the position markings are aligned on the gears to ensure the right installation of the new belt. Remove the belt by pulling the belt and simultaneously turning the engine. Install a new belt in reverse order. Check the alignment of the gear position markings.

If the belt feels very tight to install, check the right gear center to center distance.

(165.6⁺⁰_{-0.3} mm; 6.520⁺⁰_{-0.012} in)

Note 6 Cylinder head bolts tightness

Cylinder head should be tightened to 20 Nm (180 in pounds) in the first 25 hour maintenance. Dismount cooling baffles and the lower engine supporting plate.

Note 7 Decompression valves

The decompression valves must be completely tight. Crank the engine by hand and check the tightness. With closed valves the gap between the rocker axle and valve head should be 3 mm (0.1 in). The spring on the cable must return the operating lever fully. If not, lubricate the cable and check spring tension.

EIRI KY

Kisällinkatu 8
SF-15170 Lahti 17

PIK-20 E Service manual

Note 8 Spark plugs

The spark plugs must be changed twice during the 25 hours maintenance period. Maximum spark plug replacing period is 15 hours, i.e. change spark plugs every 10 to 15 hours.

Suitable spark plugs are NGK B8ES and Champion N3 can also be used.

The gap is 0.4 to 0.6 mm (0.016 to 0.024 in). The tightening torque moment is 28 Nm (250 in pounds).

Note: The spark plug protector must be locked to the engine.

Note 9 Ignition damping box check

Remove the spark plug and stick it on spark plug protector. Turn on the ignition and crank the engine. There must be a spark. Change the polarity of the cables of the ignition damping box (only for test). When the damping box is in order, there should be no spark. Change cables back to right polarity.

Note 10 Ignition

Checking the ignition timing

The timing mark is on the starter ring gear. The corresponding mark is the crankcase assembly joint on the exhaust manifold side.

Connect a timing device (lamp or buzzer) to the ignition switch wires. The timing is shown by the change in the light or buzzing tone.

The timing is right when the marks do not differ more than ± 2 mm (± 0.08 in). This corresponds to $19^\circ \pm 1,5^\circ$ BTC ($2,07 \pm 0,25$ mm)

Timing the ignition

The timing of the both ignition circuits is normally made by adjusting the contact breaker gaps within the given limits. The contact breakers can be reached from the oval holes in the magneto housing.

The armature plate is adjusted by the manufacturer and should not be turned.

If the timing can not be made by adjusting the contact breaker gaps within the given limits, inspect armature plate and the contact breakers and replace if necessary.

Change of contact breaker assembly

Remove the magneto wheel by removing the nut and using the puller. Mount new contact breaker assemblies. Adjust the gap 0,35. . . 0,45 mm (0,014. . . 0,018 in) as described above. Clean the shaft end and threads and corresponding surfaces on magneto wheel carefully. Apply Loctite 221 or equivalent on the taper and threads. Mount magneto wheel and nut. Tighten nut to 100 Nm (800 in pounds). Check ignition timing.

Note: In case of disassembling the armature plate, it is recommended to mark its position on crankcase.

Note 11 Muffler shock mounts

The attachment points of the muffler are dampened with silicone rubber shock mounts. When mounting the muffler it should be checked that the attachment points are laying evenly on the supports when the muffler pipe is in the exhaust pipe.

Use silicone rubber sheets if needed.

Use proper distance sockets to have the bolt tight with proper tension in the rubber.

Note 12 Engine shock mounts

The condition of the shock mounts affects the vibrations of the engine. The rubber bushings should be in proper condition, change the bushings when needed. The nut must always be tightened to the socket.

Note 13 Engine retracting mechanism

The retracting crank in the cockpit is uppermost when the engine is fully retracted and extended. The locks on the chain prevent the crank going over these positions. The force, when retracting the engine fully and bringing the lever against the lever lock in the chain, must be less than 200 N (45 lb). If the force is greater, examine the control system carefully before adjusting the chain.

PIK-20 E Service manual

The extended position is adjusted with the lever against the chain lock and by tautening the safety wire.

Note 14 Engine brake

When the engine doors are closed, there should be about 1 mm (0.04 in) gap between the brake lining and magneto wheel gear disc.

When changing linings, remove the old lining and clean the surfaces carefully with grade 100 sanding paper. Bond the new lining with epoxy glue. The new lining is best to be fitted on its own place by leaving it in press with the engine doors open. Avoid too thick glue layer. Do not turn the engine until the glue is hardened.

Normal automobile brake lining material can be used.

Note 15 Lubricating the retracting mechanism

In many hinges there are holes for a grease press. Grease containing molybdenum sulphite is recommended.

Note 16 Adjusting the idling

Synchronize the movement of the throttle valves by adjusting the idling position screws and cables. The mixture screws should be opened about a 3/4 turn (5/8 to 7/8).

Warm up the engine and adjust it to run about 2000 rpm by turning the throttle idle position screws equally. Try to make the engine run smoother by turning the mixture screws within the limits one at a time. To check that the both cylinders are running equally, open one throttle at a time and listen if this affects the run equally. When the idling is adjusted, check the synchronizing of the throttles.

PIK-20 E Service manual

4.2.5 Torque moments on the engine

Spark plug	28 Nm	250 inch pounds
Cylinder head nuts	20 Nm	180 inch pounds
Magneto nut	100 Nm	880 inch pounds
Toothed belt driving gear bolt	50 Nm	440 inch pounds
Bolts M 12	50 Nm	440 inch pounds
M 8	24 Nm	210 inch pounds
M 6	10 Nm	90 inch pounds

4.2.6 Engine removal

Remove the engine controls, choke, decompression and throttle.

Remove the fuel feed line hoses from the carburettor and the return line hose from the connection tube at the carburettor hose. Cover the free ends.

Disconnect the electric wires by opening the plug at the rectifier. Disconnect the on-line plug on the ignition switch cable at the root of the pylon. Pull the cable through the pylon. Disconnect the electric cable from the starter. Disconnect the thermal lead by opening the two screws on the wire.

Remove the propeller.

Remove the bolt holding the lower engine shock mount.

Unscrew the nuts holding the upper engine shock mounts and remove the 45 kg engine.

4.2.7 Trouble shooting

1. The engine does not start

No fuel: Check the fuel flow to the carburettors. Check first the function of the fuel pumps. With the electric fuel pump on, the sound of the circling fuel can be heard from the carburettors. If there still is no smell of gasoline in the carburettors when starting, the membrane needle valve, situated in the membrane house, should be cleaned. When starting in cold weather: the choke does not close fully.

No ignition spark: Check the spark by removing the plugs and by connecting the plug to the cable. Disconnect the ignition damping box cab-

PIK-20 E Service manual

les. Crank the engine by throwing from the propeller. Try to move the propeller fast over the horizontal and vertical positions. If there is no spark with the old spark plugs, try with new ones.

If there still is no spark, it is possible that the grounding cables do not disconnect or there is a short circuit from the cable to the engine.

The cable connections can be defective on the coil.

Check the spark plugs, cables and ignition system and see that contact breakers are in proper condition.

The engine is flooding: Use the decompression and crank the engine with the starter until there is a spark.

Or: Use full throttle and crank the engine until it starts.

If the engine is flooding continuously, turn the electric fuel pump on and look into the carburettor venturi. If the gasoline is flooding, clean the membrane needle valve.

2. The engine is too hot

The fuel nozzles are dirty.

The fuel flow is insufficient.

The fuel filter is dirty.

The cooling air ducts are damaged.

The spark plugs are defective.

The ignition timing is incorrect.

3. The engine is not running with full rpm

The fuel flow is insufficient.

The carburettors are dirty.

The throttles do not open fully.

The choke does not open fully.

The spark plugs are defective.

The contact breakers are in improper condition.

The decompression valves are not sealed.

The fuel pump drive line (impulse line) is dirty or leaking (check with electric fuel pump).

The engine is running on one cylinder:

Try if both cylinders are hot. If not, check the ignition and fuel flow of the cold cylinder.

EIRI KY

Kisällinkatu 8
SF-15170 Lahti 17

4.2.8 External power

If the battery is dead, an external power source can be used when starting the engine.

If the glider has a battery mounted in the engine compartment, the engine compartment doors must be open to reach the battery terminals. Disconnect or loosen the engine brake in order to be able to crank the engine with the doors open.

Use a 12-volt auxiliary battery and connect the terminals with the battery cables. Be careful to connect positive terminal to positive and negative to negative. Start the engine normally and disconnect the auxiliary battery when the engine is running. Stop the engine when it is warm enough to start with its own battery and connect the engine brake.

When the glider has the battery mounted below the instrument panel, it is also equipped with wires for a jumper cable connection. An auxiliary battery can then be connected to the wires and the engine started as described above.

NOTE

The engine must not be run without a battery because the alternator may then produce high voltage peaks.

4.2.9 Preserving the engine

When the engine is stored for longer periods without use (over 2 months) the engine must be preserved as follows:

- warm up the engine
- spray 20 ccm (0.8 oz) special preserving oil (Shell: Ensis, BP: Protective Oil, Mobilarma 524 or equal) to carburettors and stop the engine
- turn the engine by hand until the compression feels higher
- cover carburettors and exhaust pipe
- drain the fuel system

Especially when the engine is stored during the winter period, the conditions can be rather corrosive without preserving. When the engine use per year is little, good care lengthens the life of the engine.

PIK-20 E Service manual

4.3 Sailplane maintenance

4.3.1 Before assembly

Clean and grease fittings marked with "x" in the Fig. 4.2.

4.3.2 Weekly inspection

Clean the cabin and wheel box eg. with a vacuum cleaner.

4.3.3 Monthly inspection

- Make a careful daily check.
- Inspect the cockpit and sailplane construction, specially the belly, wheel house doors, skin and bulkhead bondings.
- Check the play, function and friction of all control systems.
- Inspect the control mechanisms and attachments in the central fuselage.
- Inspect the water tanks and assure that there is no water in the wings.
- Clean and grease the tail wheel.
- Sign the monthly check in the log book.

4.3.4 Annual inspection and maintenance

- Inspect the composite constructions of the sailplane.
- Inspect carefully the bondings for cracks and cracks in the paint. The cracks in the paint may be marks of defects in the structure.
- Clean and lubricate bearings and hinges marked with "o" or "x" in Figure 4.2 with grease and check the play (max 0.1 mm) in hinges, bearings and rod ends.
- Protect the flap and aileron hinge pins with lithium base grease.
- Clean and lubricate the fittings marked with "x" in Figure 4.2 and check the play (max 0.1 mm).

Most of the items which needs greasing have lubrication holes. They can be lubricated with a greasing press without removing the item.

Grease containing molybdenium sulphite is recommended. All the rod ends and the main part of the bearing bushings are lined with PTFE or acetal and need no lubrication. Other lubricate than lithium base grease must not be used in PTFE or acetal lined bearings.

EIRI KY

Kisällinkatu 8
SF-15170 Lahti 17

PIK-20 E Service manual

- Inspect the ends of the rudder cables and especially the section going through the S-tube. Inspect the guide hose for wear. Change cables after 1000 flight hours.
- Inspect the Bowden control cables of the tow release, wheel brake and the pedal adjustment and the push-pull cables of the cabin ventilation and the water ballast valve.
- Inspect the tow release coupling (see Tost Tow Hook Manual).
- Inspect the landing gear, wheel brake bearings and wheel doors. Check the play in the landing gear control mechanism. It must not be over 10 mm (when the gear is unlocked). Check that the knuckle is slightly tightened when the gear is locked in the extended position. Check that there is at least 10 mm space between the wheel and wheel doors, when the gear is locked in the retracted position.

If the glider is provided with a spring loaded landing gear, the spring washers can be inspected by removing the spring protecting tube.

- Inspect the tail wheel.
 - Clean the pitot static and compensation systems with low pressure air (0.3 bar, 4 psi). In the pitot line the use of an automobile in-line fuel filter is recommended.
 - Inspect the instrumentation tubing for leaks.
 - Check the control surface deflections (see Flight Manual 1.2 ...1.4).
 - Inspect the water tanks and ballast system for leaks.
 - When the sailplane is assembled, check the locking of the airbrakes one at a time (release the other airbrake operating rod). The force on the handle has to be reasonable (about 20 lbs).
- continued...

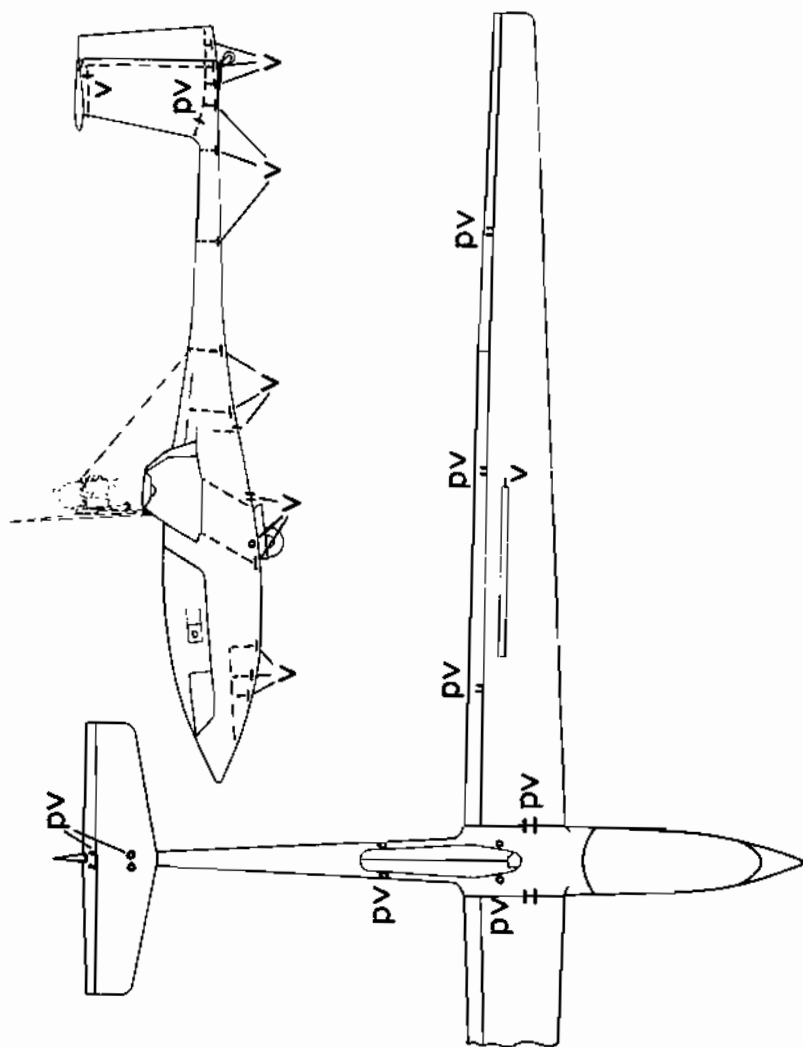
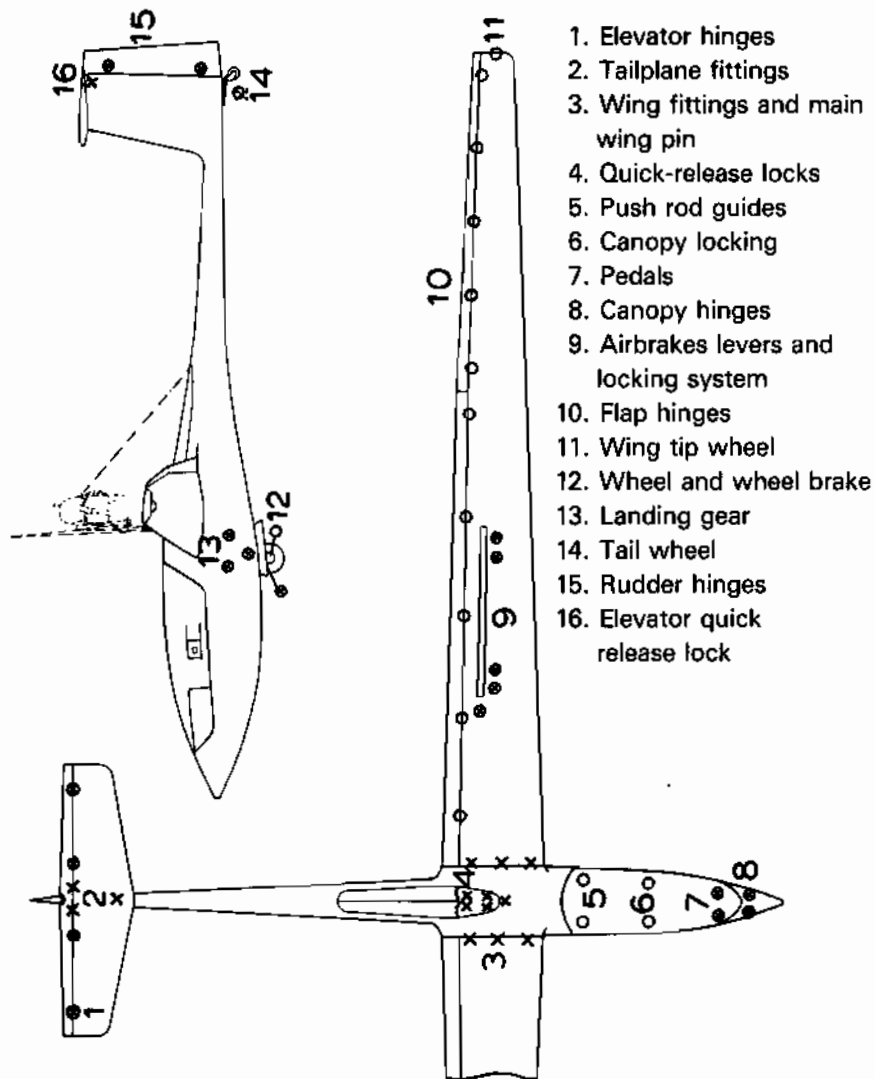

FIG 4.1: Water drain (v) and pressure relief holes (p)



1. Elevator hinges
2. Tailplane fittings
3. Wing fittings and main wing pin
4. Quick-release locks
5. Push rod guides
6. Canopy locking
7. Pedals
8. Canopy hinges
9. Airbrakes levers and locking system
10. Flap hinges
11. Wing tip wheel
12. Wheel and wheel brake
13. Landing gear
14. Tail wheel
15. Rudder hinges
16. Elevator quick release lock

FIG 4.2: Lubrication scheme

- x Clean and grease before assembly
- o Clean on annual inspection
- Clean and grease on annual inspection

EIRI KY

Kisällinkatu 8
SF-15170 Lahti 17

PIK-20 E Service manual

The locking position can be adjusted from the short control rod in the brake box by unscrewing the lock nuts and by screwing the rod 20–30° at a time (both ends are right handed with different thread pitch). The small inspection hole is for to have enough thread in the push rod.

To minimize the locking force, the right airbrake should close some 3 mm before the left one. Adjust from the quick release lock. When closed there must be 3–5 mm space between the control lever and control stop in the cockpit.

- Check the free play of the moving control surfaces to be less than the following:
 - 1 Elevator a) stick locked ± 3 mm
b) the push rod in the fin locked ± 1 mm
 - 2 Flaps stick and flap lever locked:
 ± 5.0 mm from flap to flap
 ± 2.5 mm from aileron to flap
 ± 2.5 mm moving together both flaps up and down
- Repaint the damaged parts to protect the glassfibre construction.
- Inspect the water drain and pressure relief holes (see fig 4.1).
- Sign the annual inspection in the log book.

Note: When the cockpit floor has been installed, the free movement of all controls must be checked for all positions.

4.4 After gear-up landing and after rough landing

If you make a gear-up landing, inspect the skin and ribs of the front fuselage and clean and inspect the tow coupling.

After a rough landing inspect the main landing gear and tail wheel carefully. If the tail wheel is damaged, inspect also the rudder hinges.

Note: If the sailplane is damaged, the structural repair schemes are given in the PIK-20 E Repair Manual.

4.5 Balancing of control surfaces

Always when the control surfaces have been repaired or repainted, the balancing of the control surfaces must be done.

PIK-20 E Service manual

Remove the control surfaces while balancing. The balancing is made by suspending the control surface at the hinges and then measuring the weight at the surface trailing edge with a sensitive scale. The control surface must be horizontal in order to get a correct result.

The moment (product $F \cdot a$) and the total mass m must be within the given limits.

	Moment (kgmm)	Total mass (kg)
Alleron	46— 61	1.8—2.3
Flap	119—154	3.7—4.9
Rudder	52— 68	4.0—5.3
Elevator	41— 51	1.8—2.3

FIG 4.3: Balancing of the control surface

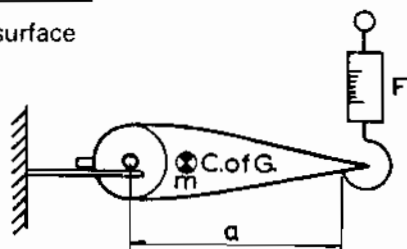

m = total mass of the control surface (kg)

F = the scale reading (kg)

a = the distance between the scale supporting point and the hinge line (mm)

$F \cdot a$ = moment (kgmm)

Note: The given moment of the rudder balances also the tail wheel. That is why a tail wheel of the same weight as the original wheel must be used.

Note: After having replaced the cockpit floor and flap and trim position plate, it must be checked that the stick moves freely with all flap positions.

EIRI KY

Kisällinkatu 8
SF-15170 Lahti 17

5. WEIGHT AND BALANCE

5.1 General

The sailplane has been weighed with the equipment marked with "x" in the Equipment list (see Service Manual 7.). The results of weighing by the manufacturer are given in the Weight and Balance Data Sheet (supplement of Flight Manual). After changing the equipment or fixed nose or tail ballast the sailplane must be weighed again to get the new actual weight and moment. These changes can also be taken into account by calculations. The result must be recorded in the flight Manual 6.4. The equipment list markings must also be updated.

5.2 Weighing procedure

5.2.1 Preparation

- Ensure that all items marked in the sailplane equipment list are installed in their proper location in the sailplane.
- Drain the water ballast system and fuel tank.
- Retract the engine.
- Remove dirt, moisture, foreign objects such as rags and tools from the sailplane before weighing.
- Weigh the sailplane inside a closed building to prevent errors in scale readings due to wind.

5.2.2 Weighing

- Level the sailplane (see figure 5.1). Levelling means: Slope of top surface of rear fuselage between stations 4.5 m and 5.5 m 1000 to 28 tail down.

Datum: Vertical plane 2.113 m (83.19 in) forward of the first wing fitting tube forward surface.

- When the sailplane is leveled, record the weight shown on each scale. Deduct the tare, if any, from each reading.

PIK-20 E Service manual

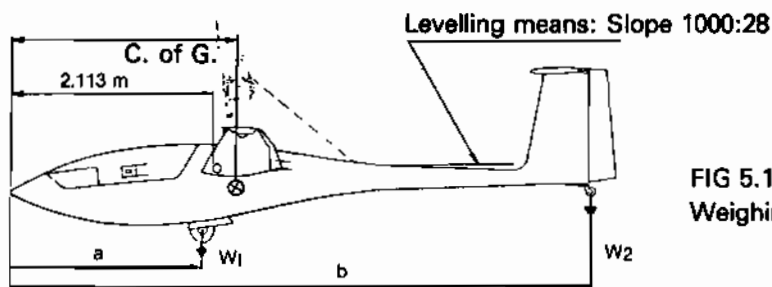

FIG 5.1:
Weighing

Scale Position on Symbol	Scale Reading (kg)	Tare (kg)	Net Weight (kg)
Main wheel (W_1)			
Tail wheel (W_2)			

Empty weight and moment	Net weight (kg)	Arm (m)	Moment (kgm)
W_1		$a = 2.116$	
W_2		$b = 6.290$	
Unusable fuel	0.7	1.810	1.3
Actual empty weight		C. of G.	

$$\text{C. of G.} = \frac{W_1 a + W_2 b + 1,3}{W_1 + W_2 + 0,7}$$

C. of G. position limits are minimum 2,267 m (also with engine extended) and maximum 2,443 m (engine retracted).

If the "Actual pilot weight range" -criteria is used by loading, calculate the minimum and maximum pilot + parachute weights according to 5.4.

70 kg and 110 kg corresponding minimum and maximum pilot + parachute can be used if the empty weight C. of G. corresponding actual empty weight is between the limits given in Figure 5.2 and in the C. of G. table.

EIRI KY

Kisällinkatu 8
SF-15170 Lahti 17

PIK-20 E Service manual

Empty weight kg	C. of G. limits	
	Fore m	Aft m
300	2,640	2,672
305	2,634	2,669
310	2,628	2,665
315	2,622	2,661
320	2,616	2,658
325	2,611	2,655
330	2,606	2,652
335	2,601	2,648
340	2,596	2,645

C. of G limits table.

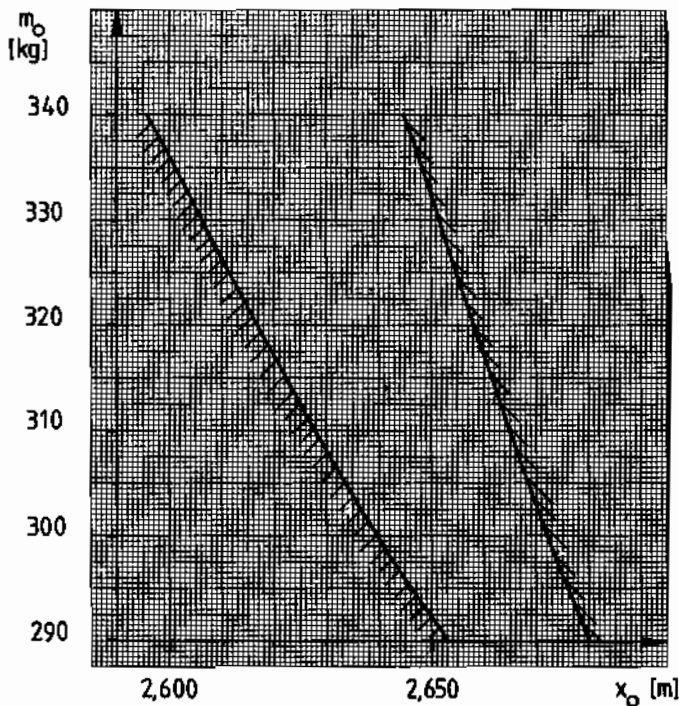

Figure 5.2. C. of G. range, with different empty weights, m_0 . Minimum pilot 70 kg, max. pilot 110 kg (incl. parachute).

EIRI KY

Kisällinkatu 8
SF-15170 Lahti 17

5.3 Calculations for actual empty weight and moment

To calculate the actual empty weight and moment after a change in equipment or ballast use the Sample Problem 5.5 as follows:

1. Write down the empty weight and moment according to the last weighing document in appropriate columns.
2. Put the weight, arm and moment of every single changed equipment or fixed ballast weight down in proper columns. Put + sign for added and - sign for removed equipment. The moment you get by multiplying arm (m) x weight (kg) = moment (kgm)
3. Add all weights and moments taking the signs into account and thus you get the actual empty weight and moment which can be recorded in the Flight Manual 6.4.

5.4 Calculations for minimum and maximum pilot weight

(See sample Problem 5.5)

Corresponding to the backmost allowed C. of G. limit the minimum pilot weight can be calculated as follows:

$$m_{pmin} = 1.017 M_o - 2,485 m_o$$

m_p = pilot weight including parachute (kg)

m_o = sailplane actual empty weight (kg)

M_o = sailplane actual moment engine retracted (kgm)

Empty weight and moment must not include fuel or water ballast because the C. of G. of the sailplane must be within the limits also with empty tanks (both move the C. of G. backwards when emptying).

Note 1: If the sailplane's C. of G. is adjusted to be at the back limit with a pilot heavier than 70 kg, the minimum pilot weight on the main placard must be changed accordingly.

Corresponding to the foremost allowed C. of G. limit the maximum pilot weight can be calculated as follows:

$$m_{pmax} = 1.271 M_o - 2,881 m_o - 32,1$$

The effect of the maximum fuel amount and extending of the engine has been corrected in the formula. The amount of the water ballast does not affect the foremost C. of G. location.

PIK-20 E Service manual

Note 2: In any case m_{pmax} cannot be greater than 110 kg. The second limit is the max. weight for the nonlifting parts (total weight — weight of wings and water ballast).

Thus:

$m_{pmax} = 328 \text{ kg} - \text{actual empty weight (including equipment and fixed ballast)} + \text{weight of wings} - \text{weight of fuel.}$

5.5 Sample Problem: Actual empty weight and moment of the sailplane

	Sample sailplane			Your sailplane		
	Weight kg	Arm m	Moment kgm	Weight kg	Arm m	Moment kgm
1. Empty Weight x) (last weighing)	290		799.0			
2. Equipment At inst. panel	3.1	0.915	2.8		0.915	
3. Equipment in luggage compartm	1.2	2.20	2.6			
4. Nose ballast	4.0	0.25	1.0		0.255	
5. Ballast at tail wheel	-2.0	6.1	-12.2			
Actual Empty Weight	296,3	2.677	793,2			

x) See Weight and Balance Data Sheet

EIRI KY

Kisällinkatu 8
SF-15170 Lahti 17

PIK-20 E Service manual

For allowed pilot + parachute weight we get

1. Backmost C. of G. limit gives for minimum pilot:

$$m_{pmin} = 1.017 \times 793.2 - 2.485 \times 296.3 = 70.4 \text{ kg}$$

2. Maximum pilot

2.1 Foremost C. of G. limit gives

$$m_{pmax} = 1.271 \times 793.2 - 2.881 \times 296.3 - 32,1 = 122,4 \text{ kg}$$

2.2 Maximum weight of nonlifting parts gives

$$m_{pmax} = 328 - 296.3 + 2 \times 61^{x)} - 25 = 128.7 \text{ kg}$$

25 kg corresponds to the maximum weight of fuel.

2.3 Maximum allowed pilot + parachute weight

$$m_{pmax} = 110 \text{ kg (see Flight Manual 3.4)}$$

2.4 Result

$$m_{pmax} = 110 \text{ kg.}$$

(Thus maximum weight of nonlifting parts allows still about 18 kg eg. for extra equipment).

x) weight of wings, 2 x 61 kg, can be used. For actual weight see Weight and Balance Data Sheet.

6. TRANSPORTATION OF THE SAILPLANE AND HANDLING ON THE GROUND

6.1 Transportation

For transportation, the use of the special PIK-20 trailer is recommended. If the sailplane is being transported in another vehicle, the following should be checked:

- Depending on the transportation van, the sailplane may be fixed and supported by the following elements: wing spar root shanks; bushings of the fuselage for the wing attachment, bevel pins for the horizontal stabilizer attachment; undercarriage wheel (take care of the gear doors) and the tail wheel. Besides this the wing, fuselage and horizontal stabilizer may be placed in appropriate holding clamps.
- It is advisable to use nylon sleeves when using wing fitting points or horizontal stabilizer fitting points for the support.
- Fix all control surfaces using gust locks.
- Lock the air brake and flap rods using cords or rubber bands.
- Take care of that no shifting, jamming or deformation can arise and avoid entry of dirt and water into the sailplane.
- On an open trailer, protect the canopy, the area of the horizontal stabilizer attachment and the wing roots and cover the pitot tube, static pressure vents and the venturi-tube hole.
- Ensure that any component cannot move during the transportation.

For more information see 4.1: General care.

6.2 Handling on the ground

The easiest way to move the sailplane on the ground is to use the engine.

When moving it by hand the forward direction is recommended.

When moving the sailplane backwards, the sailplane's steerable tail wheel must be locked by a pin to avoid damages.

Therefore it is recommended to lock the tail wheel by the pin also when having it in hangar (remove it before taxiing). The use of the tail dolly makes the handling easier.

The sailplane shall not be pushed from the control surfaces.

PIK-20 E Service manual

7. EQUIPMENT

The following list shows the equipment items which may be installed in the PIK-20 E. Items marked "x" are included in the empty weight recorded in the latest weighing document and after changes in equipment in the latest Weight and Balance Record in Flight Manual 6.4.

Item	Part	Weight (kg)	Arm (m)	Moment (kgm)
	I Standard Equipment			
	Airspeed indicator Model:			
	Altimeter Model:			
	Magnetic compass Model:			
	Ball type slip indicator Model:			
	Tachometer Model:			
	Fuel quantity indic. Model:			
	Cylinder head temp indicator Model:			
	Safety belts Model:			

EIRI KY

Kisällinkatu 8
SF-15170 Lahti 17

PIK-20 E Service manual

Item	Part	Weight (kg)	Arm (m)	Moment (kgm)
	Seat cushion Model:			
	Mirror for checking the propeller position			
	Hour meter Model:			
	II Optional Equipment			
	Tow coupling Model:			
	Variometer Model:			
	Compensating bottle			
	Turn and slip indicator Model:			
	Variometer Model:			
	Compensating bottle			
	Variometer Model:			
	Compensating bottle			

EIRI KY

Kisällinkatu 8

SF-15170 Lahti 17

PIK-20 E Service manual

Item	Part	Weight (kg)	Arm (m)	Moment (kgm)
	Artificial horizon Model:			
	Aux. unit for Art.h.			
	Accelerometer Model			
	Radio Model:			
	Battery Model:			
	Oxygen Equipment Model:			
	Oxygen bottle Model:			
	Water ballast tanks Model:			
	Water ballast system Model:			
	Clock Model:			

EIRI KY

Kisällinkatu 8
SF-15170 Lahti 17

